



North
America

South
America

Europe

Africa

Netherlands

Asia

Australia

Non-Contact Rising Stem Ball Valve



TUV



6D-0198

CE -0038

Standard Execution

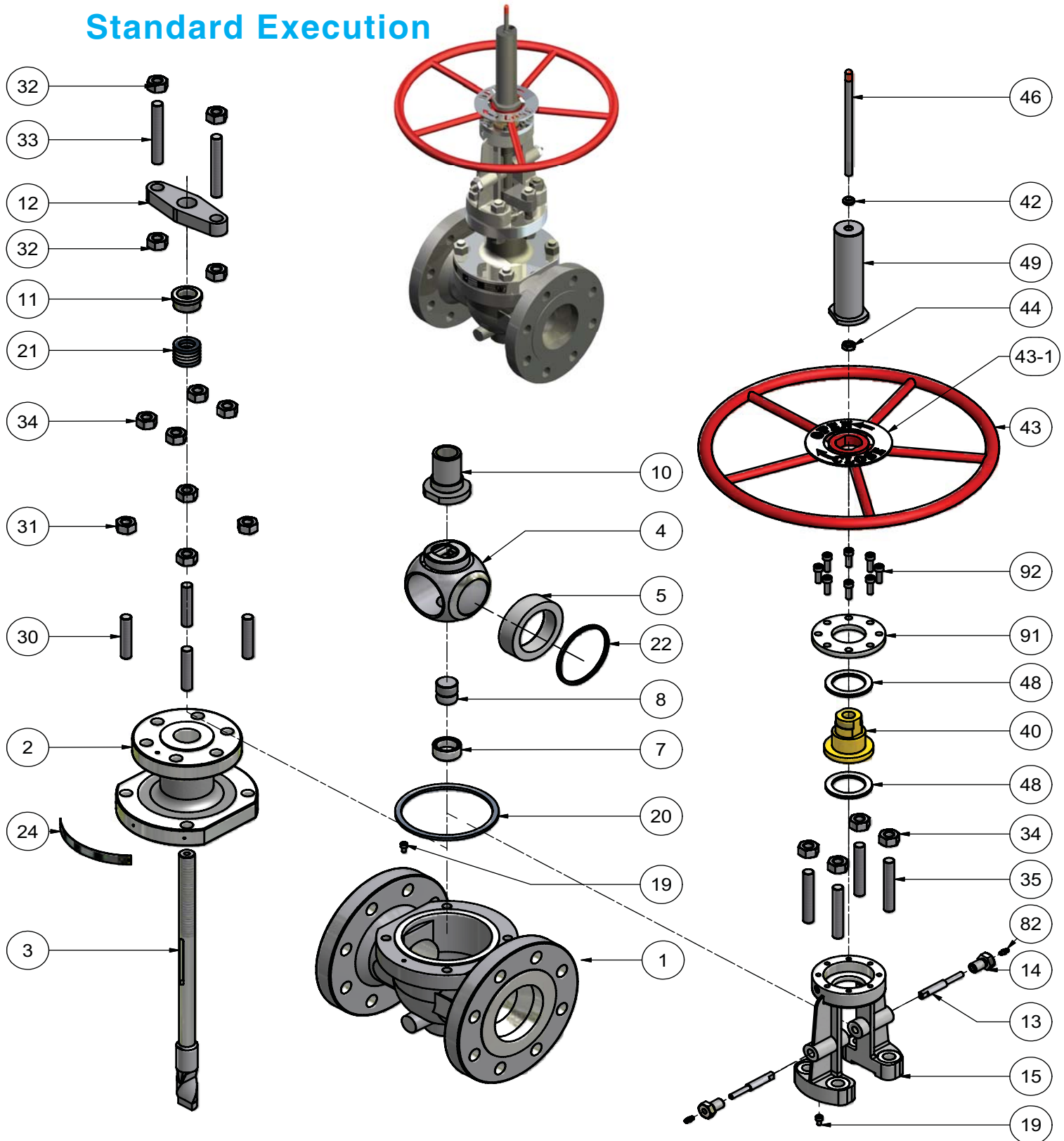

Part no.	Description
1	Body
2	Bonnet
3	Stem
4	Ball Assembly
5	Seat
7	Trunnion Bushing
8	Adjusting Ball
10	Bonnet Bushing
11	Gland
12	Gland Flange
13	Stem Guide
14	Semguide lockplate/Bolt*
15	Yoke
19	Position Bolt
20	Gasket
21	Packing
22	Seat Seal
24	Name Plate
30	Body Bonnet Stud

Part no.	Description
31	Body Bonnet Nut
32	Gland Flange Nut
33	Gland Flange Stud
34	Bonnet/Yoke Nut
35	Bonnet/Yoke Stud
40	Yoke Nut
42	Grommet
43	Hand Wheel
43-1	Open Close Direction Plate
44	Indicator Pin Locking Nut
46	Indicator Pin
48	Bearing
49	Indicator Tube
82	Grease Nipple Yoke
91	Bearing Cover
92	Bearing Cover Bolt

*Depending on valve specifications (e.g. bore, trim)

Features Control Seal™ RSBV

Friction Free

An important aspect of the lifetime of a valve is the sealing mechanism. Almost all valves, like Standard Ball, Gate, Plug and Butterfly valves have their sealing mechanism based upon shear force, friction and tearing. The Control Seal™ sealing mechanism is based upon axial movement only. The sealing is not liable to friction or tearing. This friction free quarter turn mechanical energised sealing does not generate abrasion on the seal and compared with other types of valves, it results in an exceptionally long lifetime.

Stem design

The stem of the Control Seal™ Rising Stem Ball Valve makes only a small axial movement when opening or closing. The stem is always balanced NO stem rotation occurs in combination with axial movement when opening or closing.

Stem Packing

The stem packing of the Control Seal™ Rising Stem Ball Valve can be adjusted while the valve is in service. All valves are executed with a back seat.

Inline maintenance and service

As the Control Seal™ valve is designed for easy and low cost maintenance, top-access is possible while the valve is in-line.

Non-slam

The self-locking operate mechanism on all Control Seal™ Valves, provides that the closing member can not rotate due to line forces, therefore there is no danger of line slam, shock or injury of personnel.

Fire Safe

The Control Seal™ valves have been fire safe tested by independent laboratories and have passed the test to BS6755 part 2 and API 6FA successfully. These tests have been witnessed by Lloyds on several valves.

Advantages of the Control Seal™ RSBV design

- ▶ Friction free opening and closing, increasing the lifetime of the valve.
- ▶ Single seat design, no thermal expansion problems.
- ▶ Corrosion and wear resistant materials are used on the closure members.
- ▶ Self cleaning closure members, due to high velocity flow during opening and closing.
- ▶ Top entry design for in-line inspection and maintenance.
- ▶ Adjustable stem packing while the valve is in service.
- ▶ All valves are executed with a back seat, which gives the possibility to renew the stem packing under pressure
- ▶ Mechanically energised sealing, no springs or other weak devices are required to obtain the sealing.
- ▶ Non lubricated seal.
- ▶ Pressure independent sealing.
- ▶ Stem moves only up and down, no rotation.
- ▶ No coupling cam in the stem construction
- ▶ Topworks according to ISO 5210

Materials

Control Seal™ Rising Stem Ball valves can be supplied in a variety of materials and are also available in accordance with DIN standards.

Optional valve executions

Control Seal™ can provide valves for various applications and services:

- ▶ Bellow sealed for dangerous media and zero emission.
- ▶ Stem extension for high temperature service.
- ▶ Stem extension and gas column for cryogenic service.
- ▶ Slurry and sand service (special design).

Rising Stem Ball Valve applications

Rising Stem Ball Valves are often used in the following applications:

Sand slurry service (special sand slurry design), Lethal (H₂S) service (special Bellow Seal design), Produced water service, Steam service, Molecular Sieve service, Dehydration & Regeneration service, Hydrocarbon service, Gas metering, Emergency Blow Down and Shut Down service, Hot Oil service, High Temperature service, Low Temperature service.

Opening and Closing Sequence RSBV

1. Closed position

In the closed position, the ball is tightly pressed against the seat by the mechanical camming action of the stem.

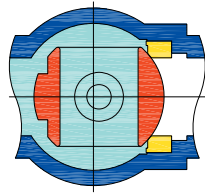

3. Rotating

As the stem continues to rise, the interaction of the stem guide and the precision spiral part at the stem causes the ball to begin its friction-free rotation.

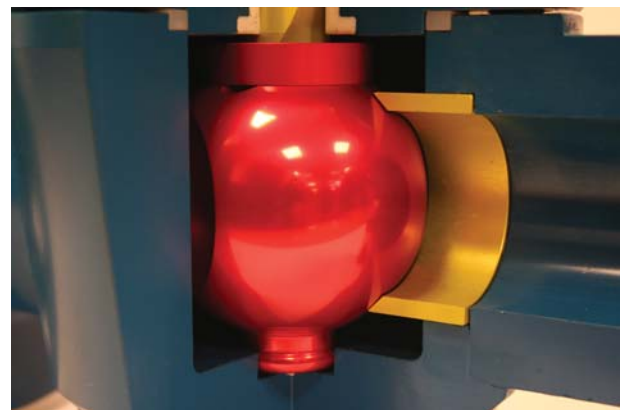
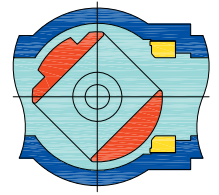

2. Opening

As the handwheel is turned counter-clockwise, as flat, sloping surface on the bottom of the rising stem causes the ball to tilt away from the seat

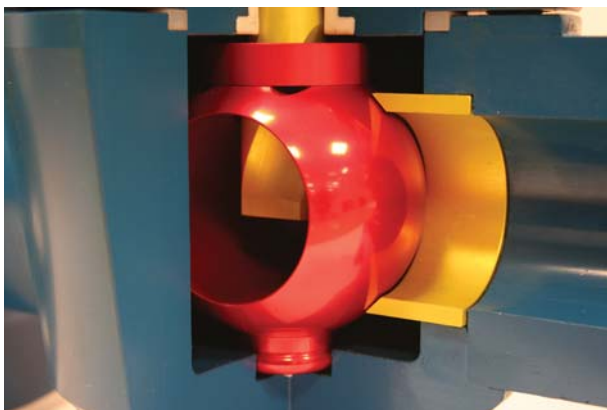
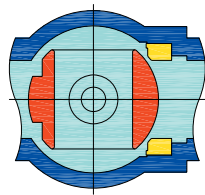

4. Opened position

In the full open position, the stem has raised to its limit and the ball is positioned for straight through flow.

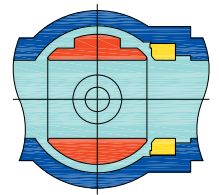

Opening and Closing Sequence RSBV

5. Closing

To close the valve, the handwheel is turned in clockwise direction. The stem begins to lower and the ball begins to rotate

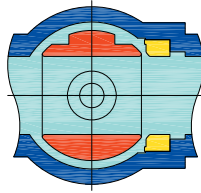

7. Sealing

Nearing the end of the closing cycle, the ball has rotated full 90 degrees without touching the seat

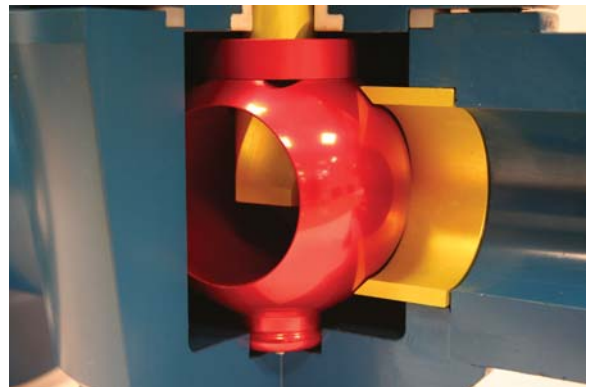
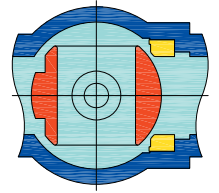

6. Rotating (2)

Continuous turning of the handwheel causes the precision spiral part at the stem to act against stem guide, rotating the ball 90 degrees

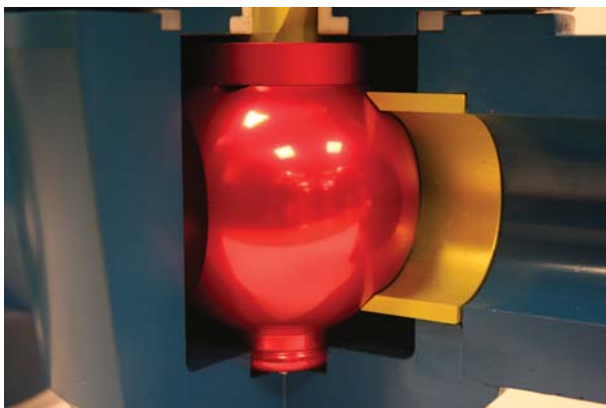
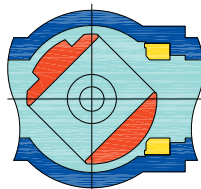

8. Closed position (2)

Final turns of the handwheel cause an angled flat surface on the lower stem to mechanically wedge the ball tightly against the seat

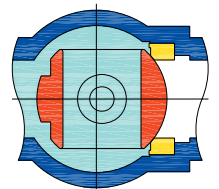

Dimensional Data - ANSI Class 150 - Full Bore - RSBV

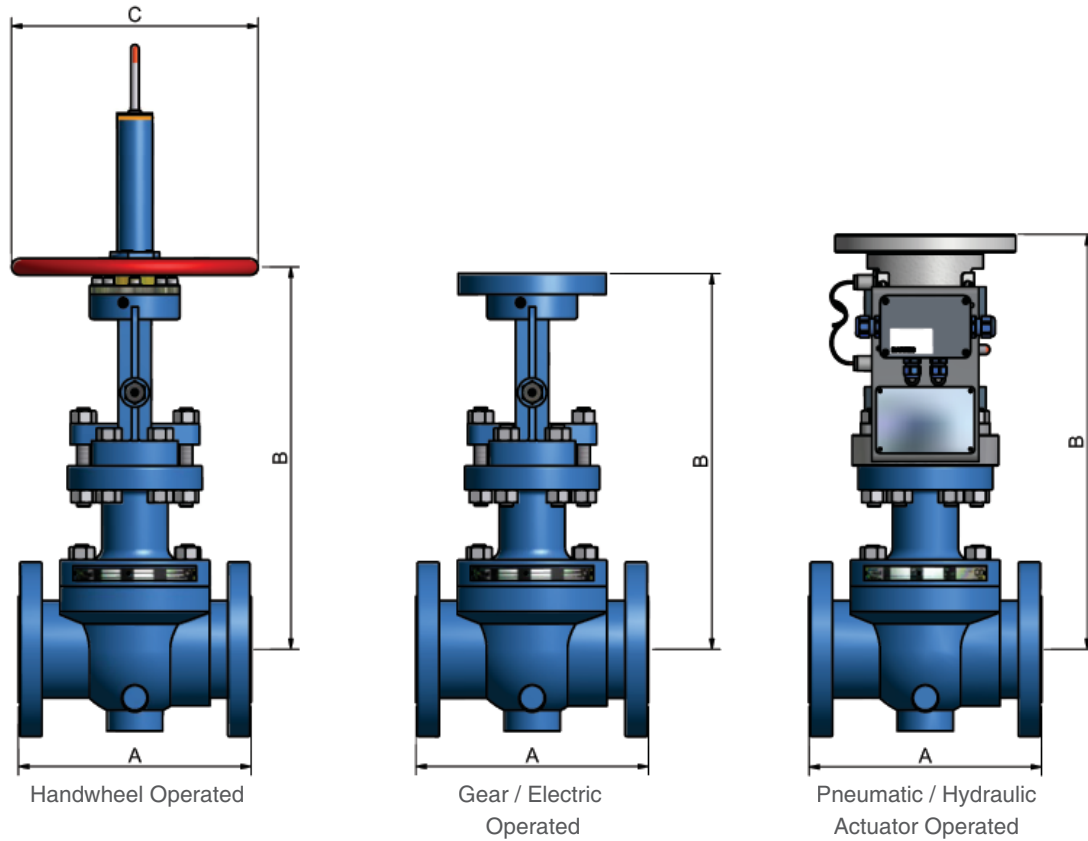

Size	A	B HO	B GO/EO	B P/H AO	C	Min. Port	Approx Weight	Approx Cv Value
[inch]	[mm] RF	[mm]	[mm]	[mm]	[mm]	[mm]	[Kg]	GPM
1	216*	409	-	451	300	25	38	60
2	178	389	-	438	300	51	35	450
3	203	459	-	498	300	76	56	1170
4	305*	545	495	593	300	102	83	2070
6	404*	-	774	781	-	152	238	4860
8	457	-	1005	1040	-	204	368	6950
10	674*	-	1177	1218	-	254	603	12005
12	762*	-	1401	1444	-	305	985	17300
14	826*	-	1402	1444	-	337	1090	28800
16	902*	-	1661	1680	-	387	1633	42100
18	915*	-	1856	1756	-	438	1775	52200
20	991*	-	1928	2003	-	489	2000	67500

Notes:

- * Dimensions and weights are for reference only. Request certified drawings when required.
- * Manufacturers standard face to face dimension, other face to face dimensions are available at option
- * Cv Values are for guidance only

Dimensional Data - ANSI Class 300 - Full Bore - RSBV

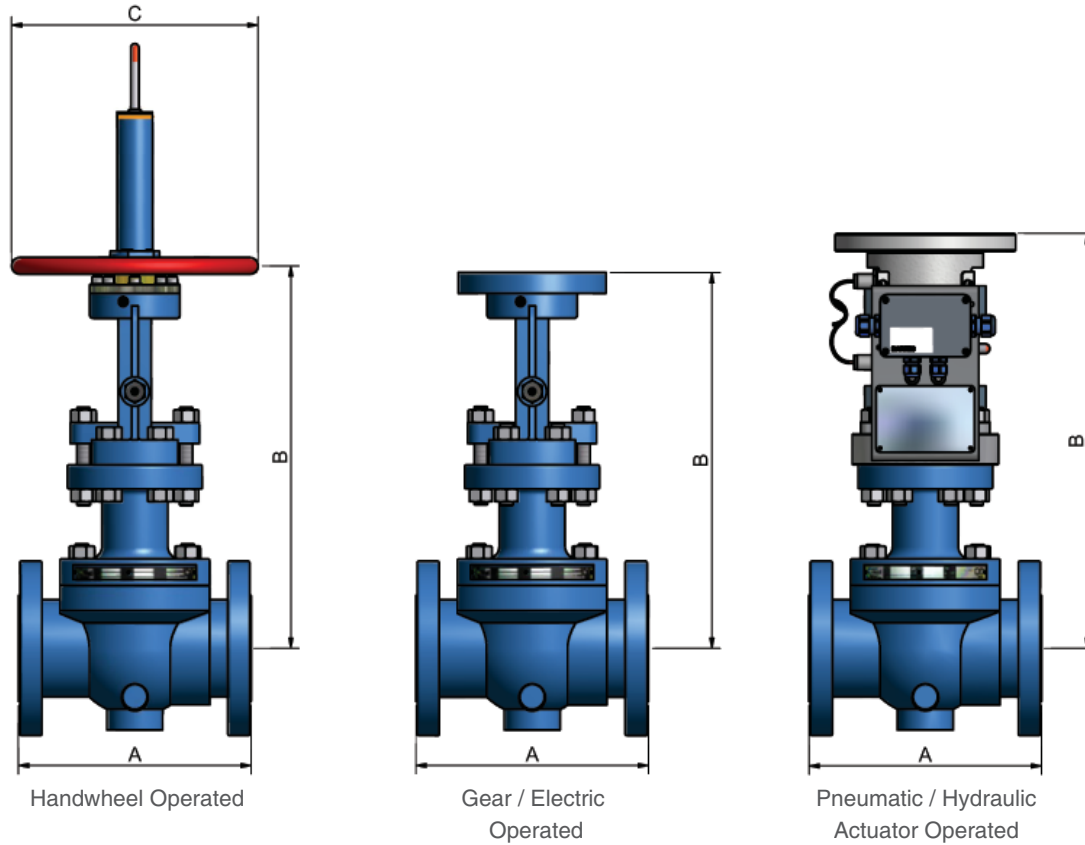

Size	A	B HO	B GO/EO	B P/H AO	C	Min. Port	Approx Weight	Approx Cv Value
[inch]	[mm] RF	[mm]	[mm]	[mm]	[mm]	[mm]	[Kg]	GPM
1	216*	403	-	378	300	25	28	60
1½	242*	396	-	431	300	38	46	140
2	216	389	-	438	300	51	34	425
3	283	469	-	498	300	76	60	990
4	305	545	-	593	450	102	90	1980
6	403	-	774	781	-	152	175	4860
8	502	-	1001	1035	-	204	300	6950
10	674*	-	1144	1180	-	254	490	12005
12	762*	-	1540	1444	-	305	840	17300
14	826*	-	1451	1630	-	337	1165	27900
16	902*	-	1604	1794	-	387	1490	42000
18	914	-	1759	1949	-	438	1650	50400
20	991	-	1911	2112	-	489	2300	64800

Notes:

- * Dimensions and weights are for reference only. Request certified drawings when required.
- * Manufacturers standard face to face dimension, other face to face dimensions are available at option
- * Cv Values are for guidance only

Dimensional Data - ANSI Class 600 - Full Bore - RSBV

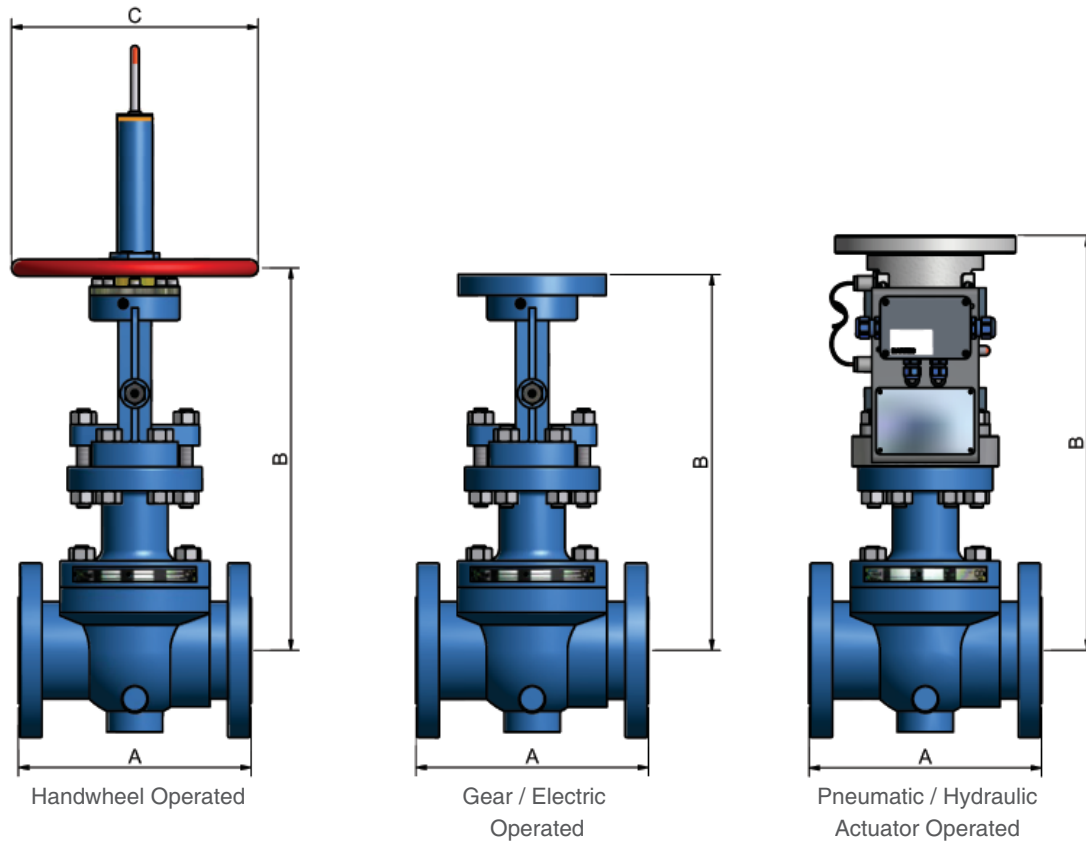

Size	A		B	B	B	C	Min. Port	Approx Weight	Approx Cv Value
	[inch]	[mm]	HO	GO/EO	P/H AO				
	[mm]	[mm]	[mm]	[mm]	[mm]	[mm]	[mm]	[Kg]	GPM
	RF	RTJ							
1	216	216	330	-	451	300	25	35	60
1½	242	242	394	-	475	300	38	40	140
2	292	295	456	-	438	300	51	50	360
3	356	359	569	-	499	300	76	68	900
4	432	435	-	654	668	-	102	140	1620
6	559	562	-	884	884	-	152	250	4050
8	660	664	-	1273	1173	-	204	445	8010
10	787	791	-	1392	1289	-	254	840	13050
12	838	841	-	1688	1602	-	305	1250	19800
14	889	892	-	1892	1630	-	337	1600	25200
16	991	994	-	1871	1942	-	387	1800	35100
18	1092	1095	-	2053	2254	-	438	2050	45900
20	1194	1200	-	2233	2434	-	489	3000	59400

Notes:

- * Dimensions and weights are for reference only. Request certified drawings when required.
- * Manufacturers standard face to face dimension, other face to face dimensions are available at option
- * Cv Values are for guidance only

Dimensional Data - ANSI Class 900 - Full Bore - RSBV

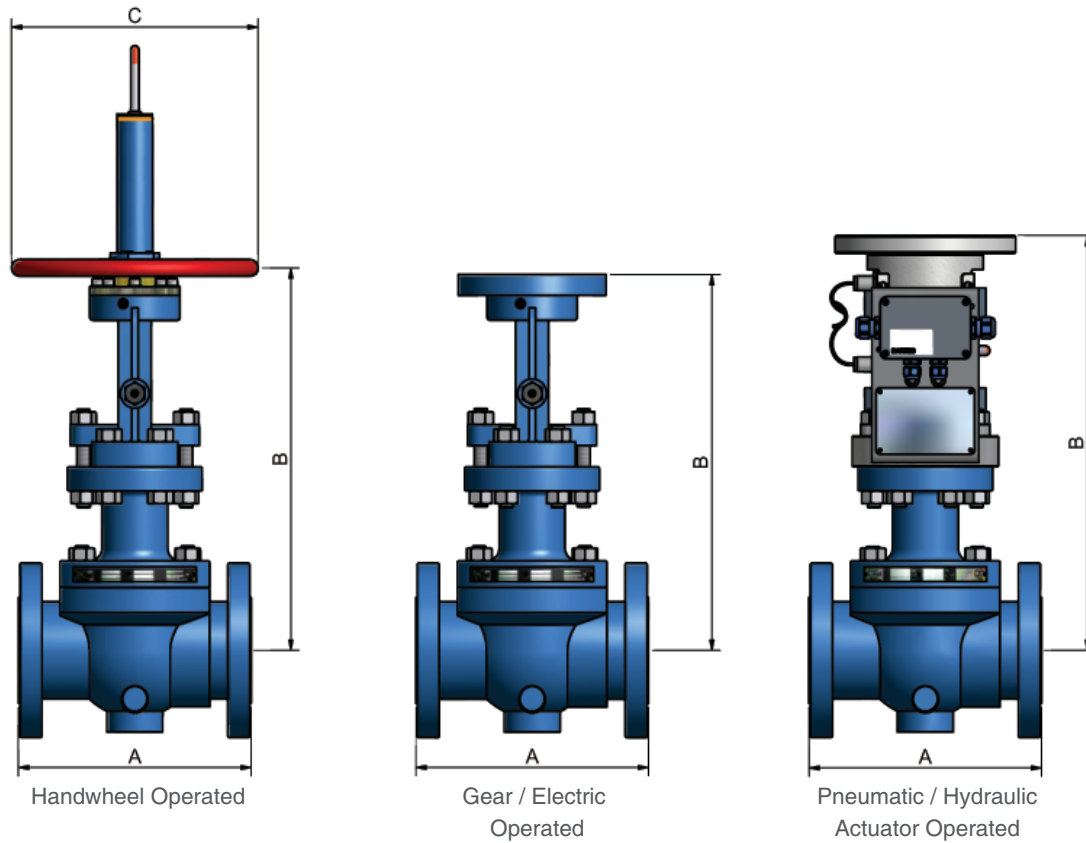

Size	A		B	B	B	C	Min. Port	Approx Weight	Approx Cv Value
	[inch]	[mm] RF	HO [mm]	GO/EO [mm]	P/H AO [mm]				
1	254	254	355	-	436	300	25	40	40
1½	305	305	425	-	506	375	38	50	120
2	368	371	-	495	586	-	51	65	325
3	381	384	-	623	577	-	76	94	910
4	457	460	-	743	949	-	102	108	1620
6	610	613	-	962	996	-	152	365	3870
8	737	740	-	1208	1472	-	204	640	7560
10	838	841	-	1515	1705	-	254	1020	10500
12	965	968	-	1725	1915	-	305	2480	14900
14	1029	1038	-	1805	2006	-	324	2668	18400
16	1130	1140	-	2010	2211	-	375	3250	34640
18	1219	1232	-	2112	2310	-	423	5509	43900

Notes:

- * Dimensions and weights are for reference only. Request certified drawings when required.
- * Manufacturers standard face to face dimension, other face to face dimensions are available at option
- * Cv Values are for guidance only

Dimensional Data - ANSI Class 1500 - Full Bore - RSBV

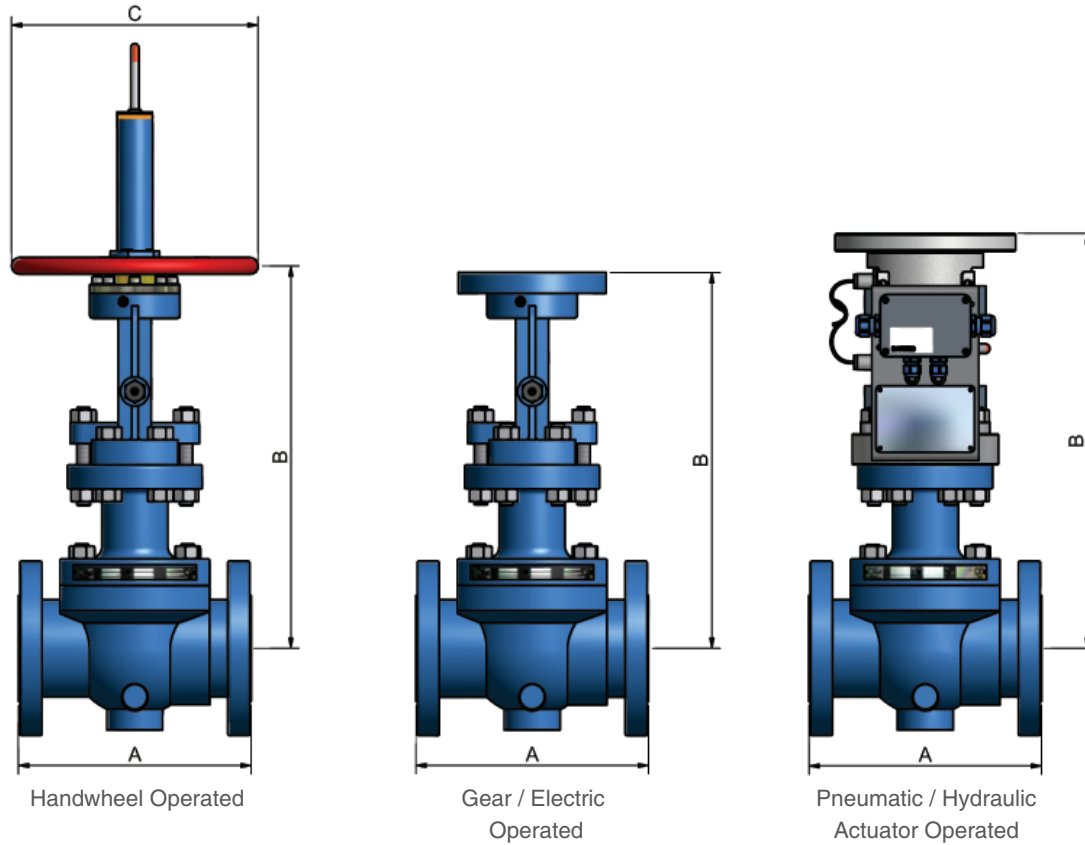

Size	A	B HO	B GO/EO	B P/H AO	C	Min. Port	Approx Weight	Approx Cv Value
[inch]	[mm] RJ	[mm]	[mm]	[mm]	[mm]	[mm]	[Kg]	GPM
1	254	389	-	470	275	25	40	60
1½	305	472	-	541	275	38	55	140
2	371	546	642	585	450	51	91	425
3	473	-	751	758	375	76	130	990
4	549	-	880	880	450	102	210	1980
6	711	-	1371	1341	850	146	640	4860
8	841	-	1725	1606	1000	194	820	6950
10	1000	-	1721	1844	1000	242	1350	12005
12	1146	-	2066	2083	1250	289	1720	17300

Notes:

- * Dimensions and weights are for reference only, Larger sizes available on request
Request certified drawings when required.
- * Manufacturers standard face to face dimension, other face to face dimensions are available at option
- * Cv Values are for guidance only

Dimensional Data - ANSI Class 2500 - Full Bore - RSBV

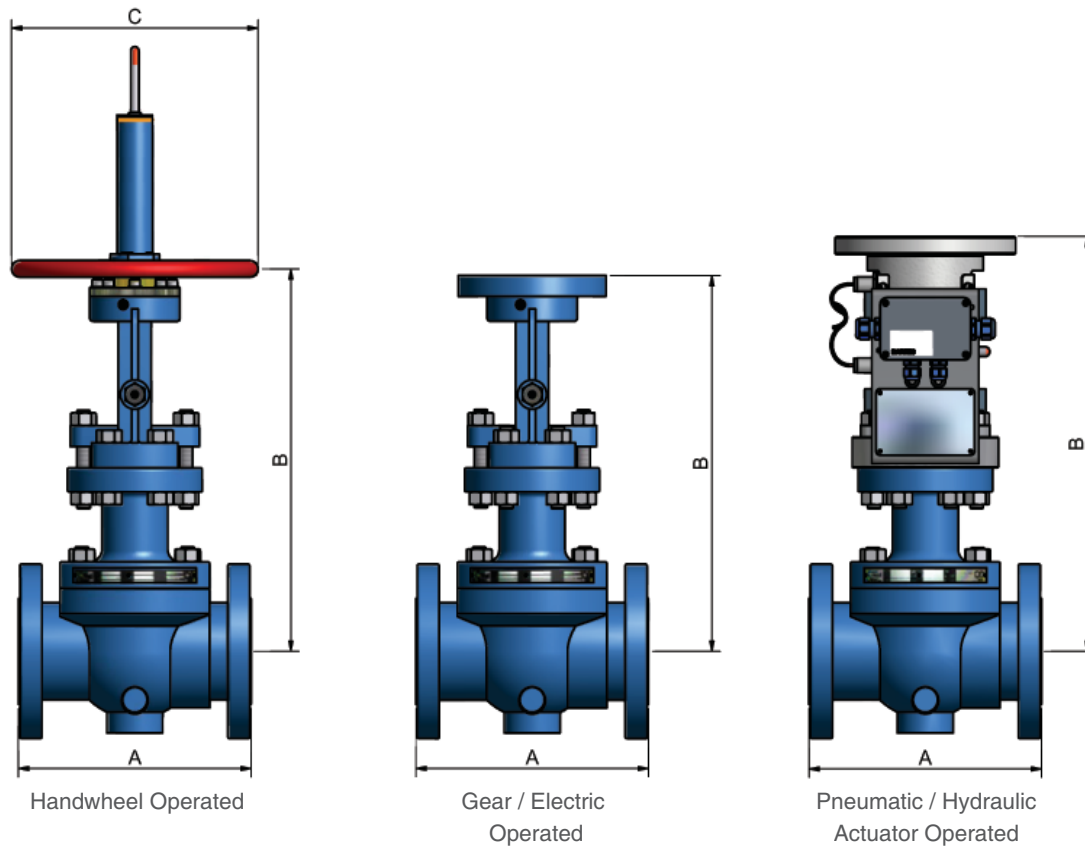

Size	A	B HO	B GO/EO	B P/H AO	C	Min. Port	Approx Weight	Approx Cv Value
[inch]	[mm] RJ	[mm]	[mm]	[mm]	[mm]	[mm]	[Kg]	GPM
1	451	430	-	499	375	25	55	35
1½	454	527	-	608	375	38	65	110
2	454	-	671	776	375	44	90	270
3	584	-	757	765	450	63	210	720
4	683	-	963	1099	450	89	315	1350
6	927	-	1508	1419	1000	133	875	3150
8	1038	-	1697	1717	1000	181	1275	6370
10	1292	-	1781	1982	1250	225	1520	9900

Notes:

- * Dimensions and weights are for reference only, Larger sizes available on request
Request certified drawings when required.
- * Manufacturers standard face to face dimension, other face to face dimensions are available at option
- * Cv Values are for guidance only

Dimensional Data - ANSI Class 150 - Reduced Bore - RSBV

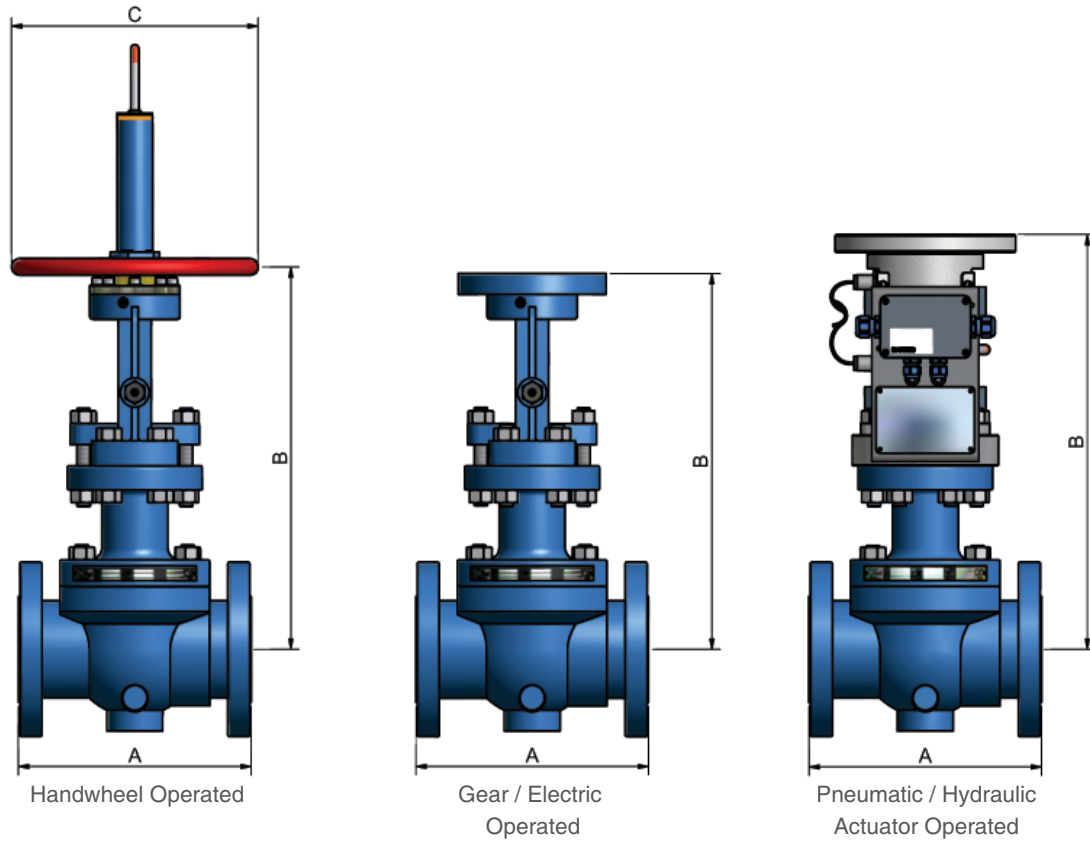

Size	A	B HO	B GO/EO	B P/H AO	C	Min. Port	Approx Weight	Approx Cv Value
[inch]	[mm] RF	[mm]	[mm]	[mm]	[mm]	[mm]	[Kg]	GPM
2 x 1½	178	396	-	431	300	38	38	150
3 x 2	203	390	-	438	300	51	35	195
4 x 3	229	460	-	500	300	76	56	540
6 x 4	394	539	-	593	450	102	83	760
8 x 6	457		774	781	450	152	238	2045
10 x 8	533		1005	1035	650	204	368	4270
12 x 10	762*		1177	1366	450	254	603	7360
14 x 12	826*		1401	1531	850	305	985	13310
16 x 12	902*		1402	1534	850	305	1090	9565
18 x 16	914*		1661	1784	1000	387	1633	21110
20 x 16	991*		1856	1795	1250	387	1775	15085
24 x 20	1170*		1928	2105	1500	489	2000	27000

Notes:

- * Dimensions and weights are for reference only. Request certified drawings when required.
- * Manufacturers standard face to face dimension, other face to face dimensions are available at option
- * Cv Values are for guidance only

Dimensional Data - ANSI Class 300 - Reduced Bore - RSBV

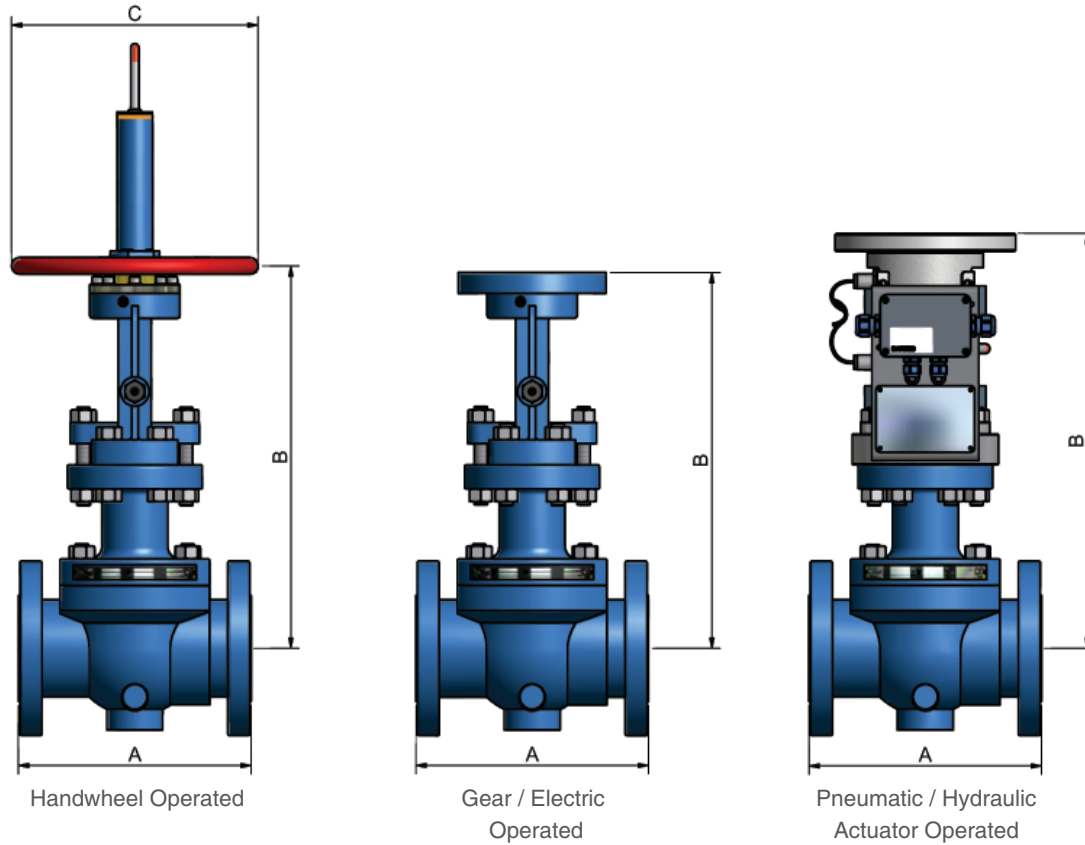

Size	A	B HO	B GO/EO	B P/H AO	C	Min. Port	Approx Weight	Approx Cv Value
[inch]	[mm] RF	[mm]	[mm]	[mm]	[mm]	[mm]	[Kg]	GPM
2 x 1½	216	396	-	431	300	38	31	150
3 x 2	283	390	-	438	300	51	42	220
4 x 3	305	460	-	500	300	76	67	555
6 x 4	404	545	639	593	450	102	111	760
8 x 6	502		774	781	450	152	210	1780
10 x 8	568		1001	1035	650	204	345	4260
12 x 10	762*		1190	1366	650	254	635	7360
14 x 12	825*		1355	1531	850	305	950	9565
16 x 12	902*		1355	1534	850	305	1030	9565
18 x 16	915*		1605	1784	1000	387	1665	13310
20 x 16	991*		1605	1795	1250	387	1745	15095
24 x 20	1143*		1915	2105	1500	489	2300	25650

Notes:

- * Dimensions and weights are for reference only. Request certified drawings when required.
- * Manufacturers standard face to face dimension, other face to face dimensions are available at option
- * Cv Values are for guidance only

Dimensional Data - ANSI Class 600 - Reduced Bore - RSBV

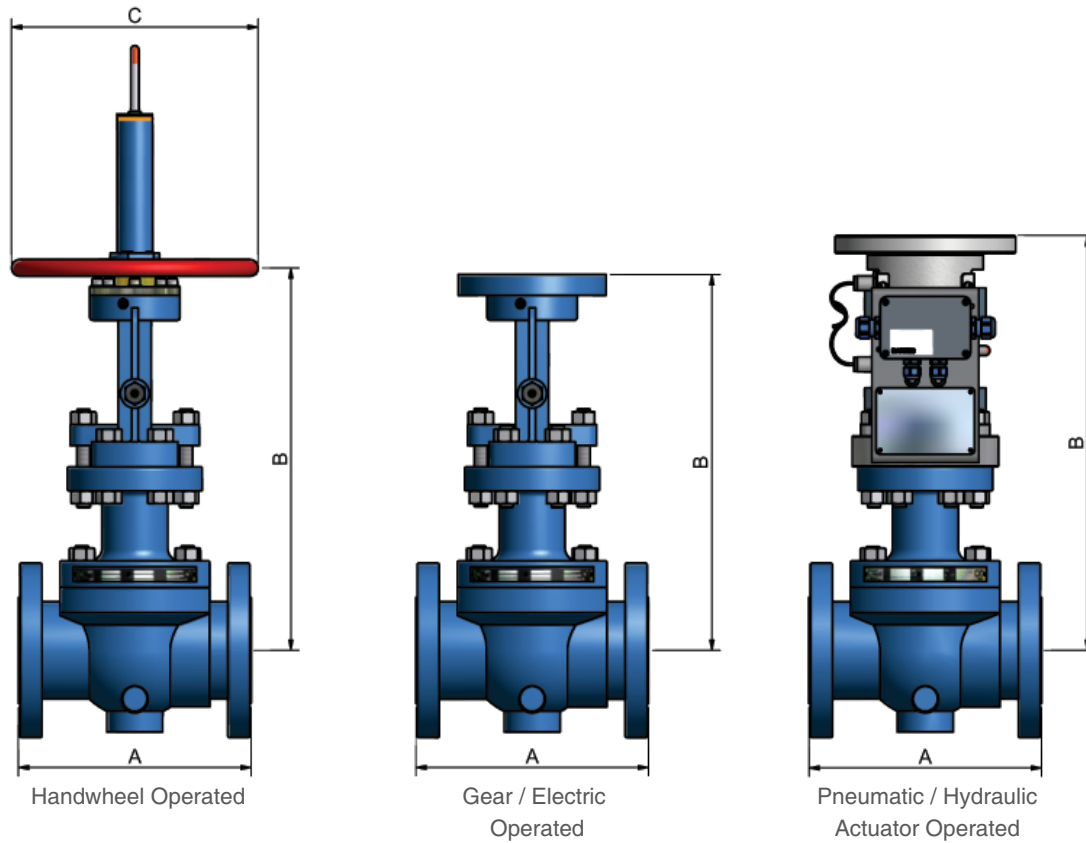

Size	A		B	B	B	C	Min. Port	Approx Weight	Approx Cv Value
[inch]	[mm] RF	[mm] RTJ	[mm] HO	[mm] GO/EO	[mm] P/H AO	[mm]	[mm]	[Kg]	GPM
2 x 1½	292	295	395	-	444	275	38	40	120
3 x 2	356	359	455	-	438	275	51	60	220
4 x 3	432	435	460	-	499	375	76	90	570
6 x 4	559	562	-	654	669	500	102	175	860
8 x 6	660	664	-	885	884	500	152	295	2010
10 x 8	787	791	-	1185	1173	850	203	520	4040
12 x 10	838	841	-	1253	1289	1685	254	935	7310
14 x 12	889	892	-	1253	1289	1000	305	1370	9510
16 x 12	991	994	-	1613	1628	1250	305	1625	13230
18 x 16	1092	1095	-	1940	2130	1250	387	1920	15720
20 x 16	1194	1200	-	1940	2141	1500	387	2045	21620
24 x 20	1379	1407	-	2295	2496	1500	489	3250	27000
			-			-			

Notes:

- * Dimensions and weights are for reference only. Request certified drawings when required.
- * Manufacturers standard face to face dimension, other face to face dimensions are available at option
- * Cv Values are for guidance only

Dimensional Data - ANSI Class 900 - Reduced Bore - RSBV

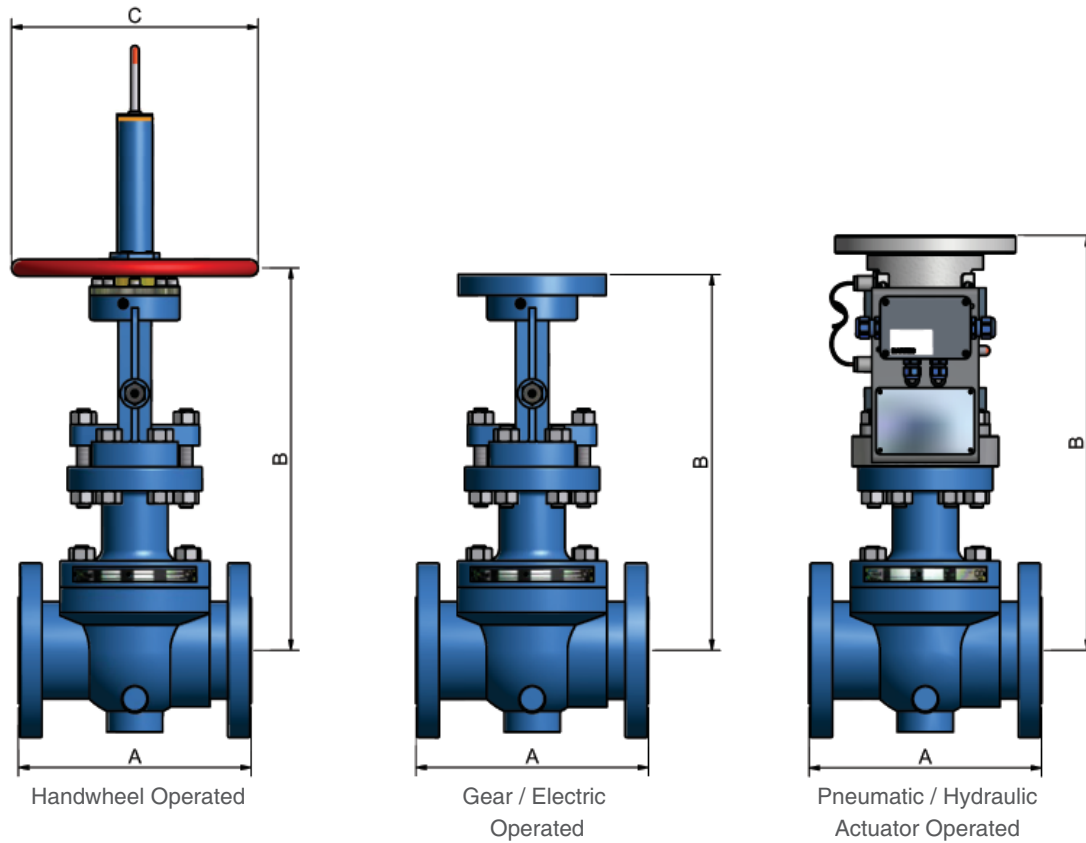

Size	A		B	B	B	C	Min. Port	Approx Weight	Approx Cv Value
	[inch]	[mm] RF	[mm] RTJ	HO	GO/EO				
2 x 1½	368	371	425	-	494	375	38	45	120
3 x 2	381	384	536	-	586	375	51	93	190
4 x 3	457	460	527	-	577	375	76	120	515
6 x 4	610	613	-	734	750	450	102	210	850
8 x 6	737	740	-	961	996	750	152	430	2460
10 x 8	838	841	-	1346	1244	1000	204	720	3955
12 x 10	965	968	-	1701	1578	1000	254	1105	6620
14 x 12	1029	1038	-	1701	1578	1250	305	1670	8535
16 x 12	1130	1140	-	2025	1912	1250	305	1770	12075
18 x 12	1219	1232	-	2032	1902	1500	375	3450	19900
20 x 12	1321	1334	-	2010	2211	1500	375	3900	20250

Notes:

- * Dimensions and weights are for reference only. Request certified drawings when required.
- * Manufacturers standard face to face dimension, other face to face dimensions are available at option
- * Cv Values are for guidance only

Dimensional Data - ANSI Class 1500 - Reduced Bore - RSBV

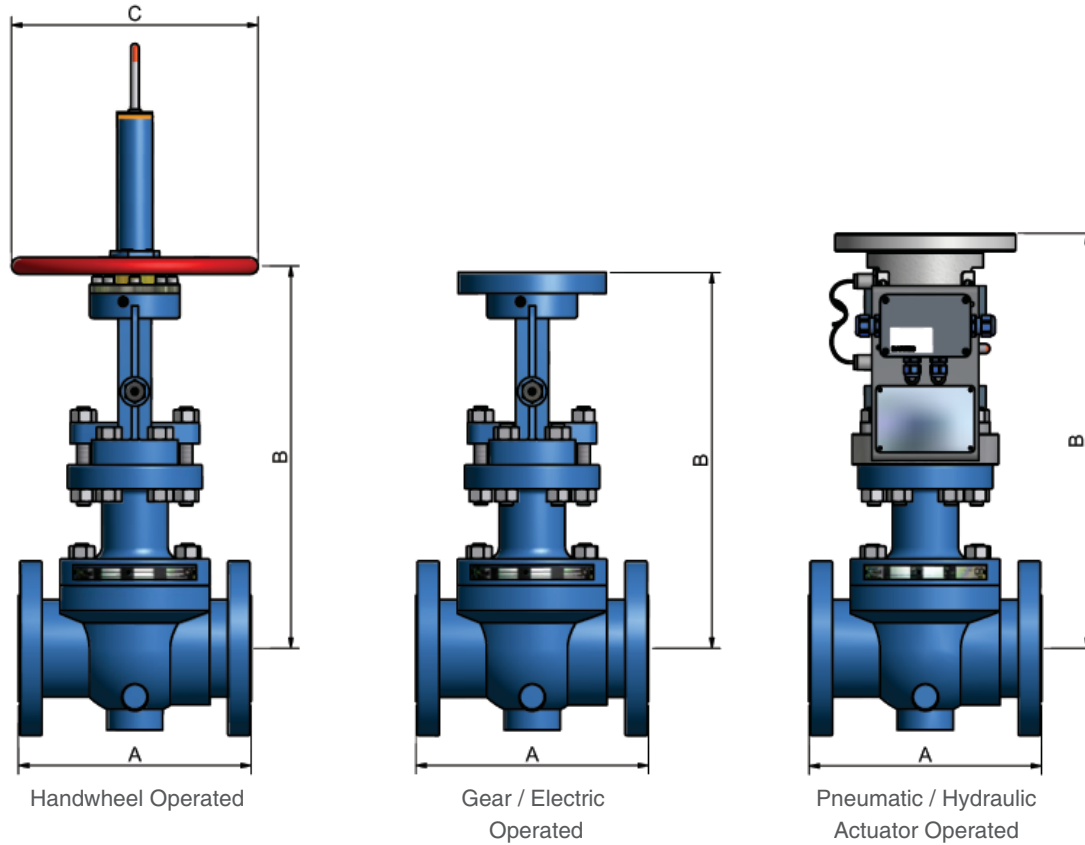

Size	A	B HO	B GO/EO	B P/H AO	C	Min. Port	Approx Weight	Approx Cv Value
[inch]	[mm] RJ	[mm]	[mm]	[mm]	[mm]	[mm]	[Kg]	GPM
2 x 1½	371	467	-	544	300	38	64	115
3 x 2	473	555	-	636	300	51	95	200
4 x 3	549	-	750	758	300	76	145	505
6 x 4	711	-	880	879	300	102	290	845
8 x 6	841	-	1198	1269	850	146	780	2045
10 x 8	1000	-	1728	1605	1000	194	1000	3760
12 x 10	1146	-	1721	1596	1000	222	1350	6290
14 x 12	1267	-	1885	2086	1250	289	2100	8110
16 x 12	1407	-	1885	2086	1500	289	2680	11475

Notes:

- * Dimensions and weights are for reference only, Larger sizes available on request
Request certified drawings when required.
- * Manufacturers standard face to face dimension, other face to face dimensions are available at option
- * Cv Values are for guidance only

Dimensional Data - ANSI Class 2500 - Reduced Bore - RSBV

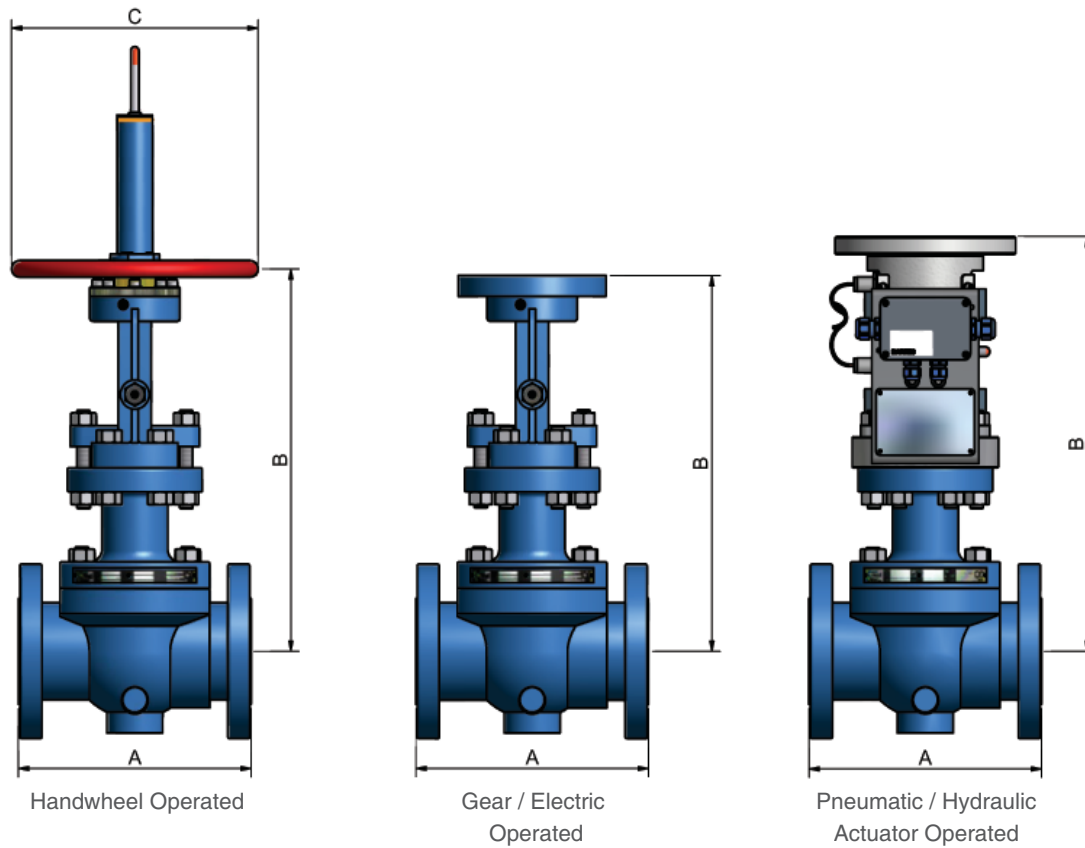

Size	A	B HO	B GO/EO	B P/H AO	C	Min. Port	Approx Weight	Approx Cv Value
[inch]	[mm] RJ	[mm]	[mm]	[mm]	[mm]	[mm]	[Kg]	GPM
2 x 1½	454	-	561	701	375	28	85	110
3 x 2	584	-	670	786	375	45	130	175
4 x 3	683	-	800	909	450	64	300	420
6 x 4	927	-	1026	1101	450	89	510	600
8 x 6	1038	-	1250	1429	1000	134	1190	1511
10 x 8	1292	-	1530	1720	1250	181	2900	3575
12 x 10	1445	-	1785	1986	1500	225	4100	5980

Notes:

- * Dimensions and weights are for reference only, Larger sizes available on request
Request certified drawings when required.
- * Manufacturers standard face to face dimension, other face to face dimensions are available at option
- * Cv Values are for guidance only

Rising Stem Ball Valves General Data

Design, dimensions according to:

- ▶ API specification 6D
- ▶ ANSI B16.34

Construction:

- ▶ 1-piece, single seat, top entry, trunnion mounted ball, antistatic design, reduced or full bore

Characteristics:

- ▶ Non contact, metal seated, rising stem ball valve.

Face to face dimensions according to:

- ▶ ANSI B16.10
- ▶ API 6D
- ▶ Manufacturers standard

Flanged connections according to:

- ▶ ANSI B16.5 Raised Face smooth finish, stock finish or Ring Type Joint
- ▶ MSS-SP-44 Raised Face smooth finish, stock finish or Ring Type Joint

Buttweld end connections according to:

- ▶ ANSI B16.25

Hub end connections according to:

- ▶ Manufacturers standard or client specification

Fire Safe according to:

- ▶ BS 6755 part 2 including AMD 6272 / 6712
- ▶ API specification 6FA & ISO 10497
- ▶ ANSI 607

Marking in accordance with:

- ▶ MSS-SP-25
- ▶ European directive PED 97/23/EC
- ▶ Optional marking to client specification
- ▶ API 6D

Testing according to:

- ▶ API 6D
- ▶ API 598
- ▶ BS 6755 part 1
- ▶ ISO-15848 Class BH/CH

Operating device:

- ▶ Handwheel
- ▶ Gearbox
- ▶ Actuator

Optional

- ▶ ATEX Cat. II 2 G/D



Control Seal™ Rising Stem Ball Valve in-line

CONTROL Seal

valve manufacturer



Dual Expanding
Double Block & Bleed
Plug Valve



Non Contact Rising
Stem Ball Valve

Axial Flow Valve



4 Way
Diverter Valve



www.controlseal.nl
Tel: +31 (0) 348 474315



Control Seal B.V.

Sales, Engineering & Services Office:
Waardsedijk Oost 10-4, 3417XJ Montfoort, the Netherlands
Phone: +31 (0)348 474 315, Fax: +31 (0)348 474 238

Head Office & Manufacturing Facility:
Farmsumerweg 43, P.O. box 330, 9900AH Appingedam, the Netherlands
Phone: +31 (0)596 652 222, Fax : +31 (0)596 629 405

E-mail: sales@controlseal.nl Website: <http://www.controlseal.nl>